

El incumplimiento de estas instrucciones exime de toda responsabilidad a TRES Grifería.
TRES Grifería décline toute responsabilité en cas d'inobservance de ces instructions.
Bei Nichtbefolgung der Bedienungsanleitung übernimmt TRES Grifería keinerlei Haftung.
Het niet opvolgen van deze instructies ontslaat TRES Grifería van alle aansprakelijkheid.
L'inadempimento di queste istruzioni esonera TRES Grifería da ogni responsabilità.
Nedodržení pokynů v návodu zbavuje společnost TRES Grifería veškeré zodpovědnosti.
Any failure to follow these instructions releases TRES Grifería from any liability.
Niezasztosowanie się do instrukcji zwalnia z wszelkiej odpowiedzialności TRES Grifería.

TRES

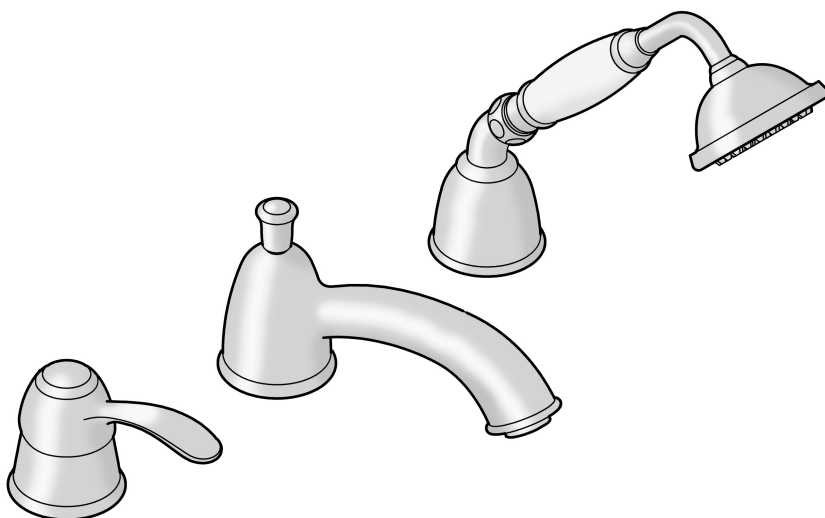

VALORES DE CONEXIÓN • VALEURS DE BRANCHEMENT • ANSCHLUSSWERTE • WAARDEN VAN DE VERBINDING
 VALORI DI CONNESSIONE • NASTAVENÍ PŘIPOJENÍ • FITTING CONNECTION SPECIFICATIONS
 CHARAKTERYSTYKI PODŁĄCZENIA • CONDIÇÕES DE CONEXÃO • ПРОМЫВКА СИСТЕМЫ

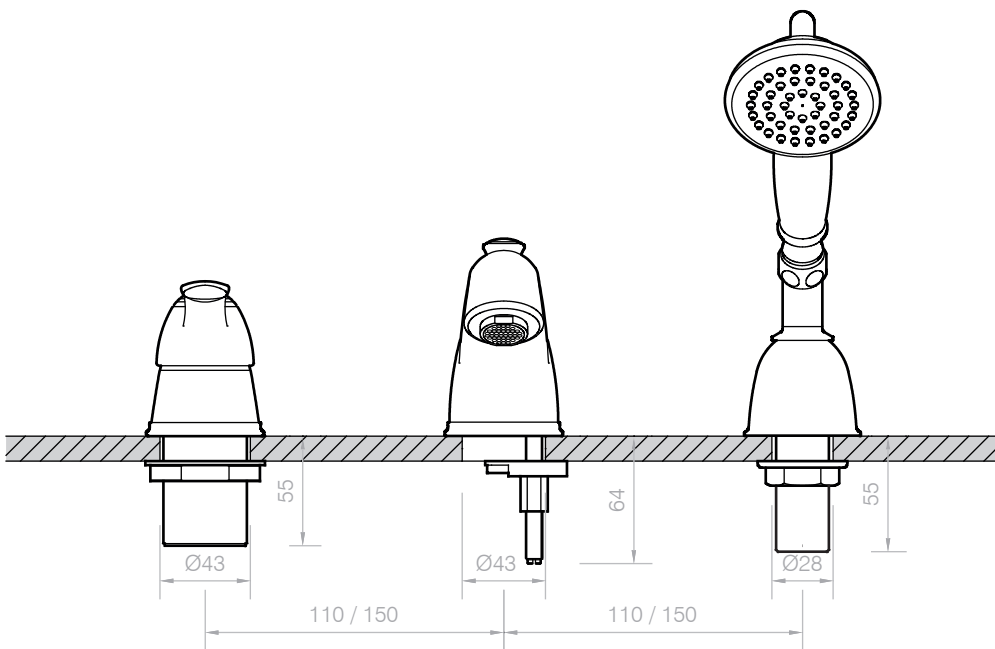
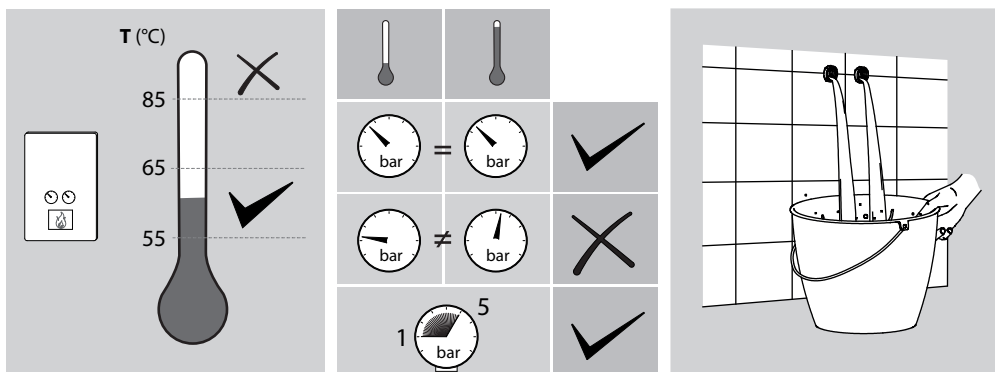

A

- No incluído
- Non fornies
- Nicht enthaltet
- Niet meegeleverd
- Non fornite in dotazione
- Nejsou součástí dodávky
- Not included
- Nie załączone
- Não incluídas
- в комплект НЕ входят

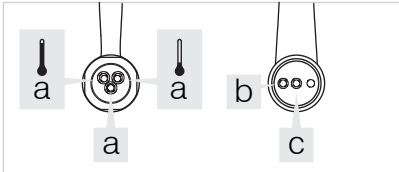
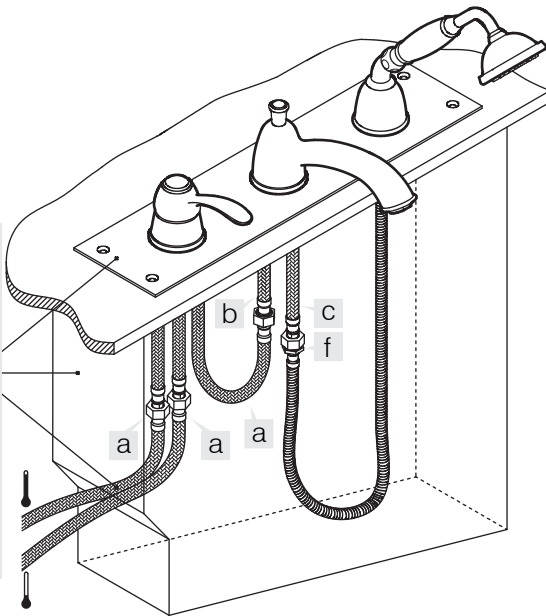
**a (x3)****G1/2"****M10x1****b (x1)****G1/2"****M10x1****c (x1)****G1/2"****M10x1****d (x1)****M15x1****G1/2"****B**

- No incluído
- Non fornies
- Nicht enthaltet
- Niet meegeleverd
- Non fornite in dotazione
- Nejsou součástí dodávky
- Not included
- Nie załączone
- Não incluídas
- в комплект НЕ входят

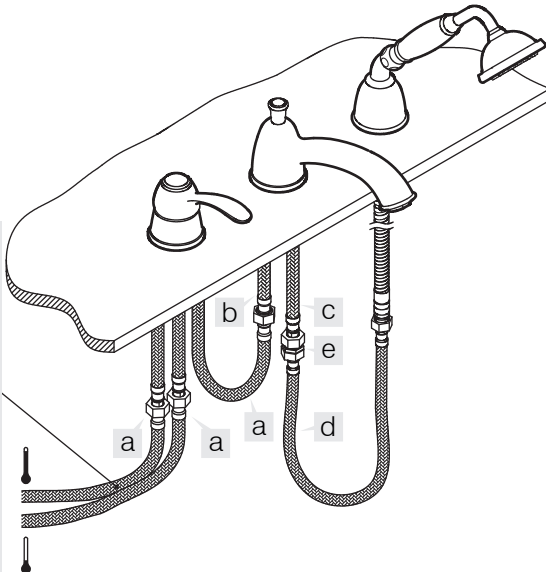
**e (x1)****G1/2"****G1/2"****f (x1)****G1/2"****M15x1**

1

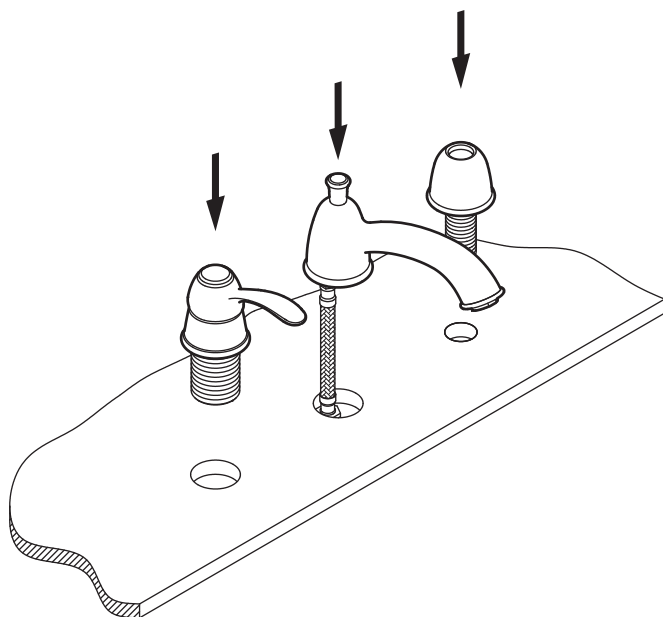

2

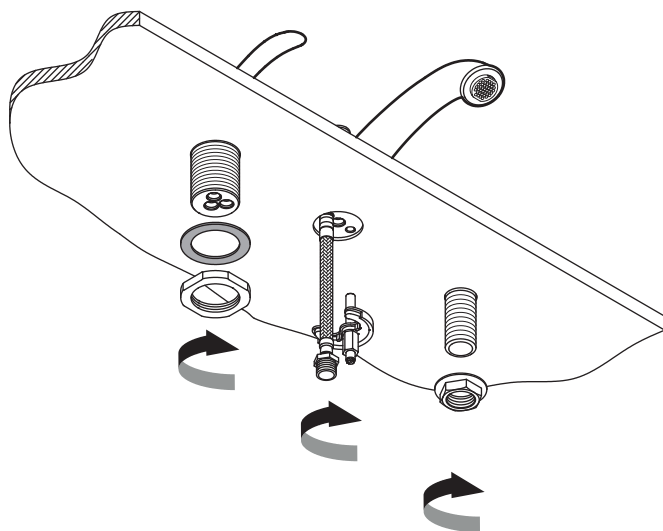

3

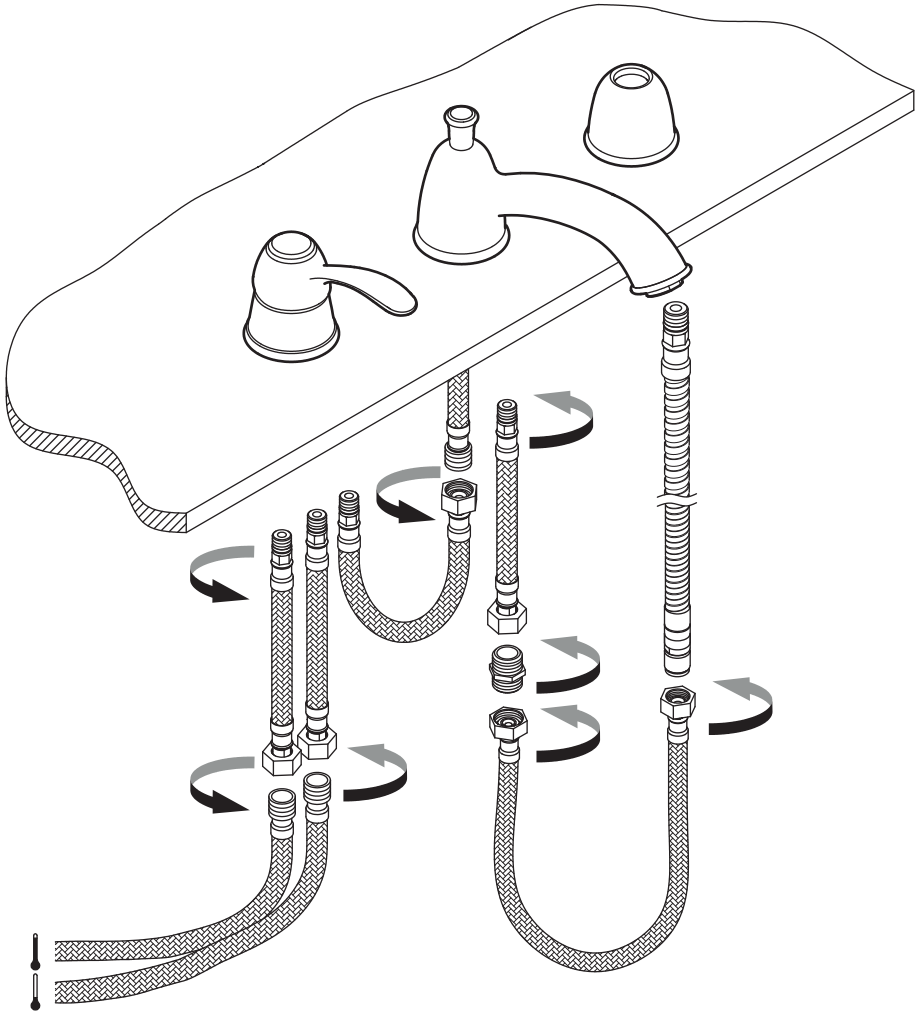

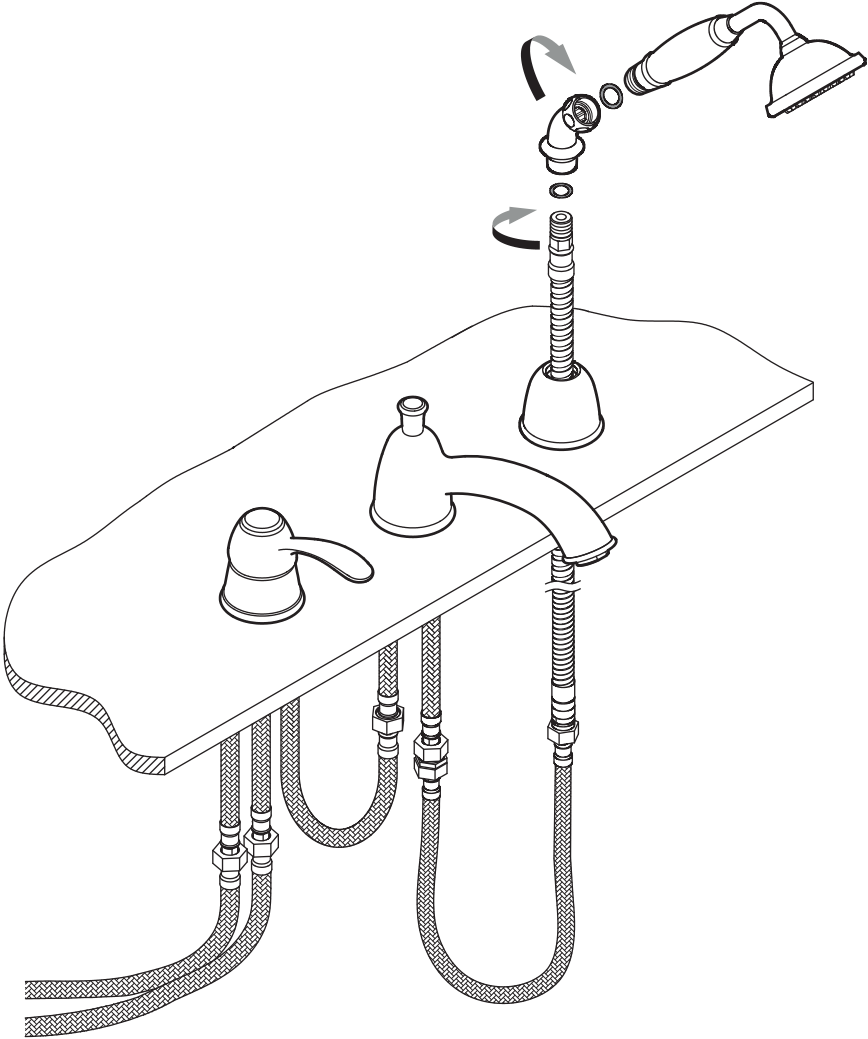

1

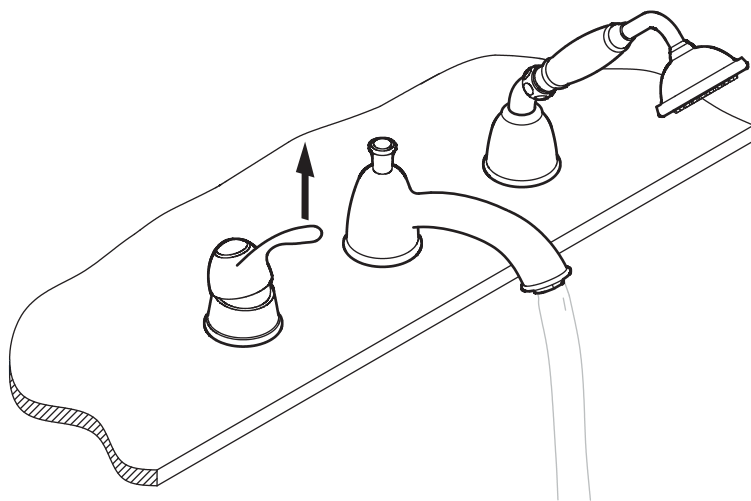

2

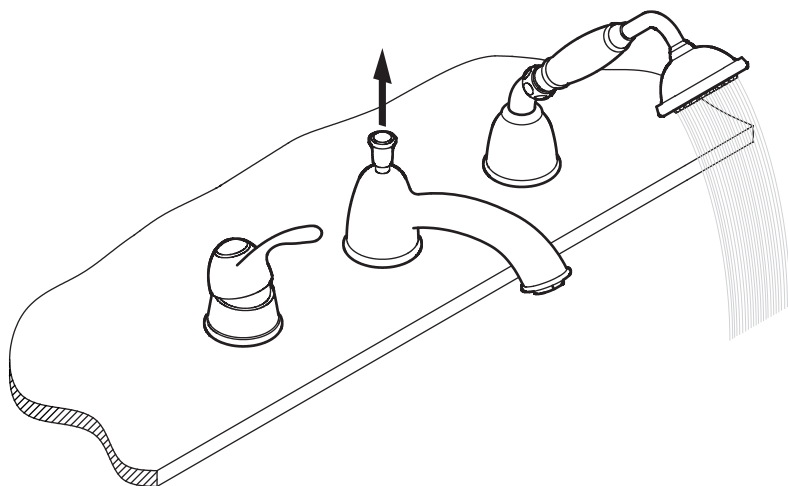

CALBRADO DE TEMPERATURA • CALIBRAGE DE LA TEMPERATURE • TEMPERATURKALIBRIERUNG • KALIBREREN
VAN DE TEMPERATUUR • TARATURA DELLA TEMPERATURA • NASTAVENÍ TEPLoty • TEMPERATURE CALIBRATION •
KALIBRACJA TEMPERATURY • CALIBRAGEM DA TEMPERATURA • КОНТРОЛЬНЫЙ ЗАМЕР ТЕМПЕРАТУРЫ

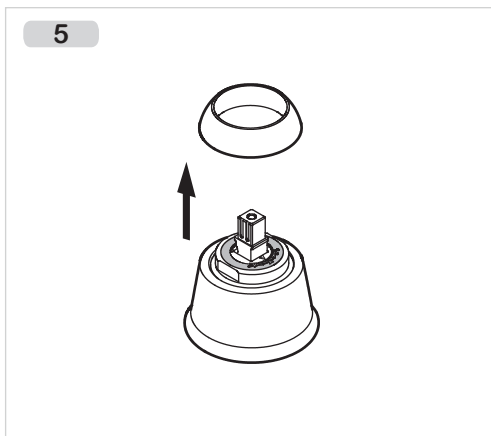
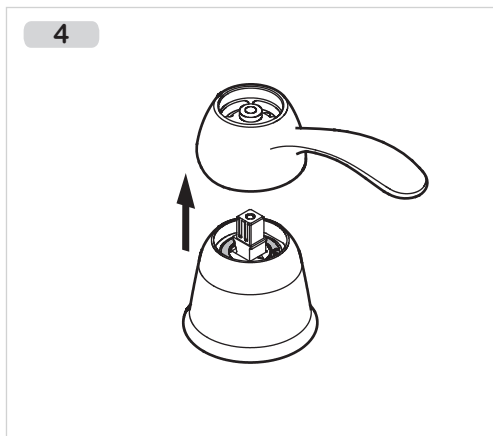
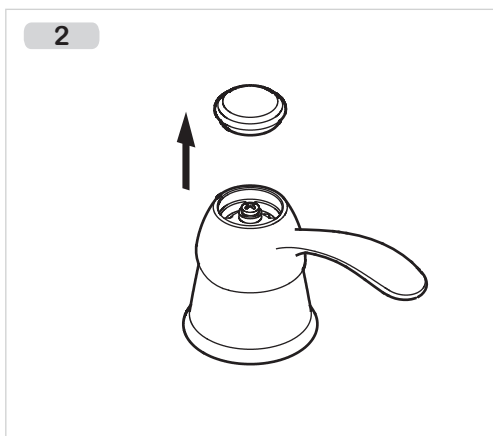
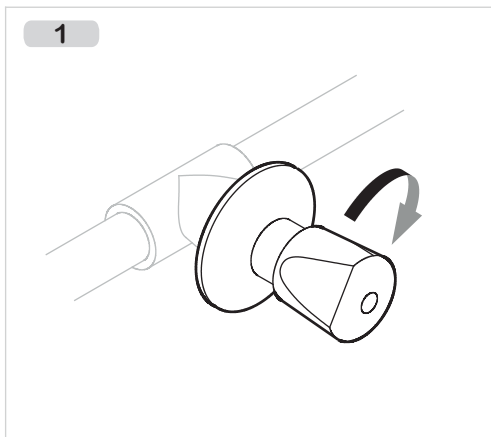
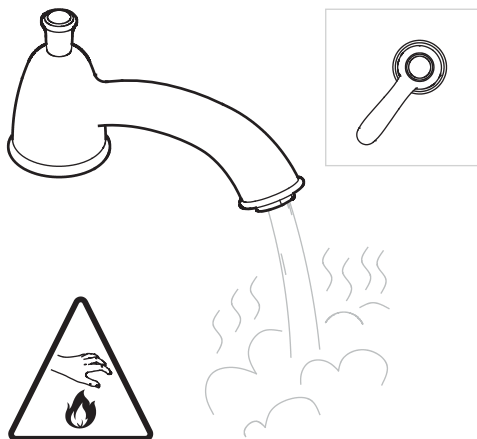

6

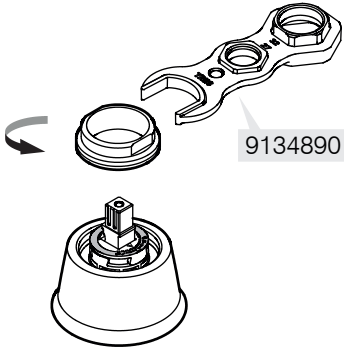

7

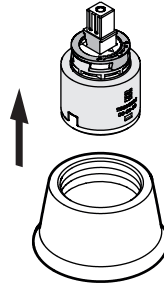

8

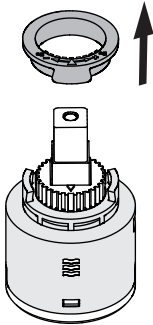

9

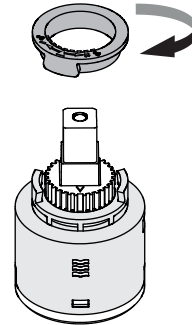

10

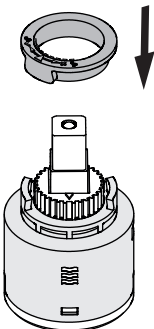

11

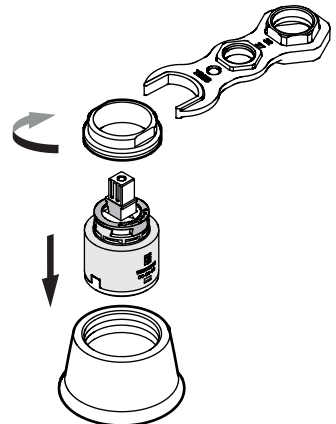

12

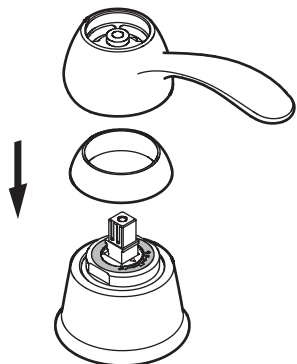

13

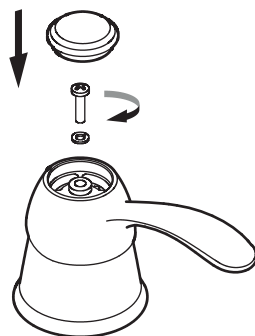

14

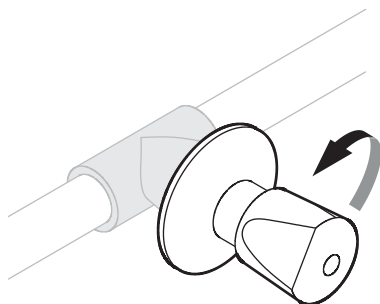

15

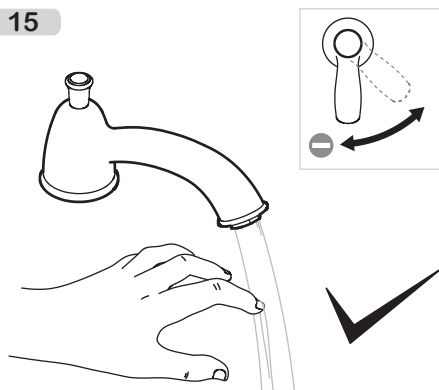

MANTENIMIENTO • ENTRETIEN • WARTUNG • ONDERHOUD • MANUTENZIONE • ÚDRŽBA
 MAINTENANCE • KONSERWACJA • MANUTENÇÃO • ТЕХНИЧЕСКАЯ ПОДДЕРЖКА

1

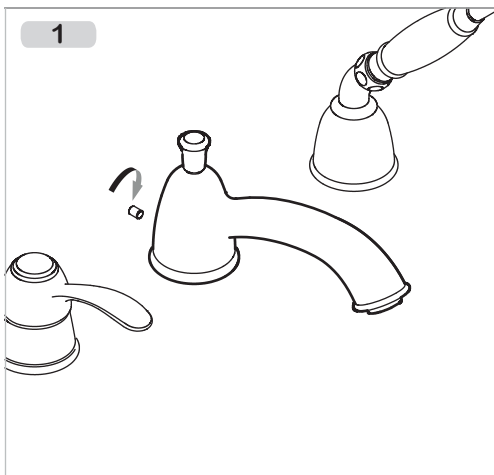

2

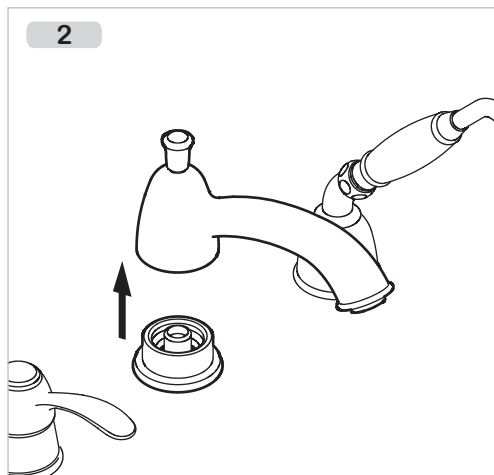

3

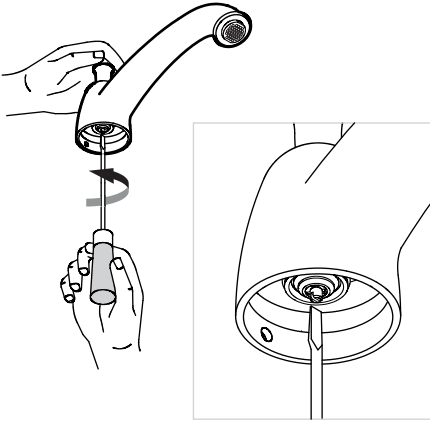

4

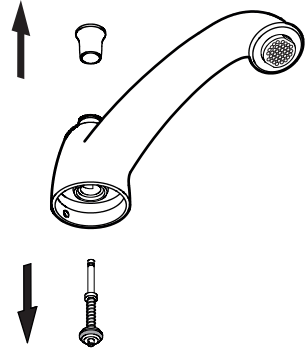

5

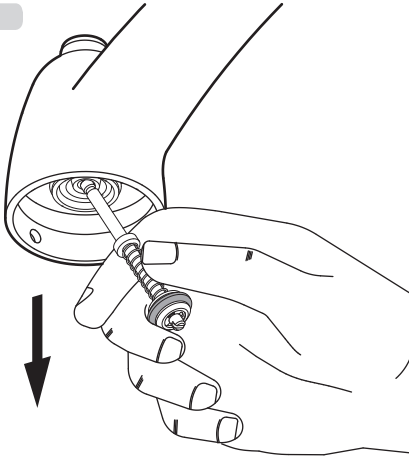

6

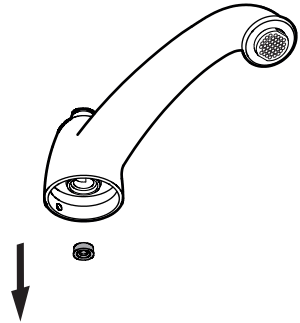

7

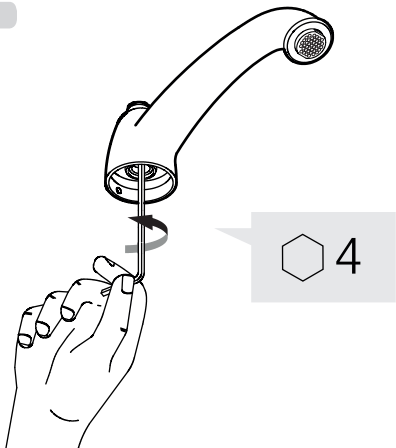

8

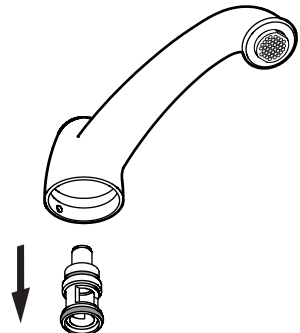

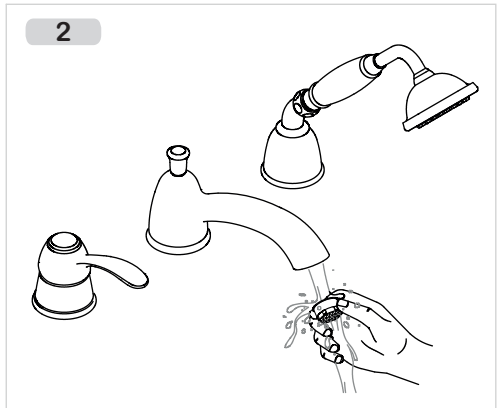
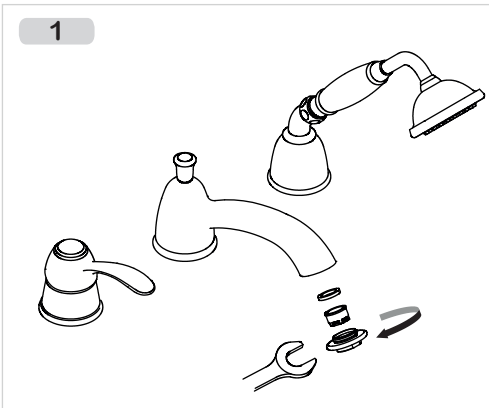
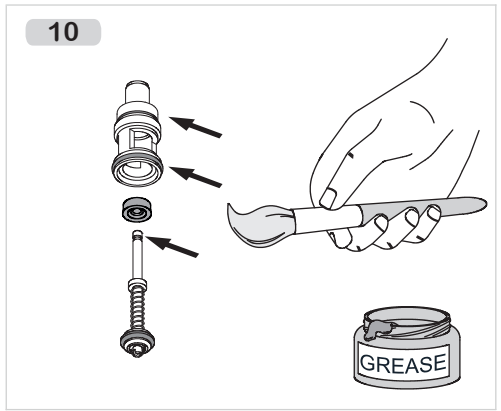
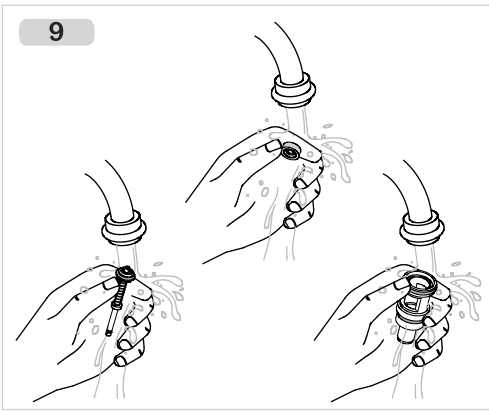

LIMPIEZA • NETTOYAGE • REINIGUNG • REINIGING • PULIZIA • ČIŠTĚNÍ
CLEANING • CZYSZCZENIE • LIMPEZA • ЧИСТКА

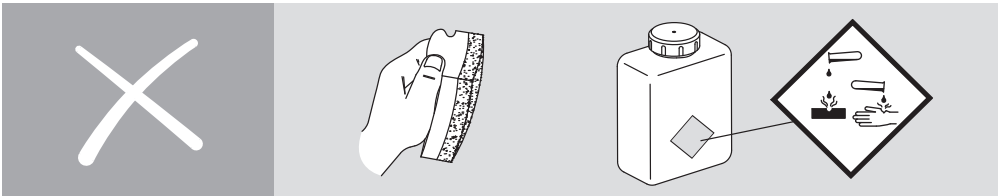
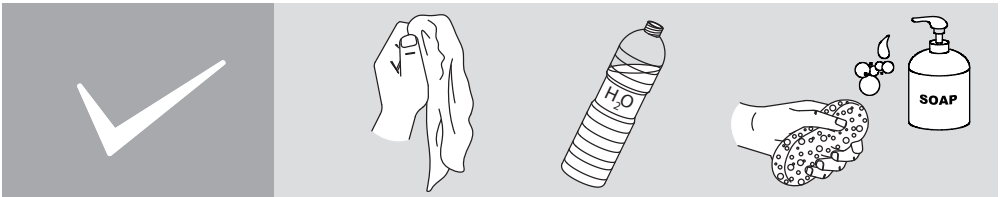

TRES

TRES COMERCIAL, SA | C/ Penedès, 16-26 • Zona Industrial, Sector A • 08759 Vallirana
Tel. (34) 93 683 40 27 • Fax. (34) 93 683 50 61 • comercialtres@tresgriferia.com • www.tresgriferia.com