

ramonsoler.

→ Ficha Técnica
Data Sheet
Fiche Technique
Technisches Datenblatt

Accesorios



Barra de ducha Polo de metal con teleducha 3 posiciones Ø90mm y flexo, cromada
982402AS

Colección: Accesorios	Acabado: Cromo	Código: 300180
Ubicación: Baño	Categoría: Ducha	

Características técnicas

- Sistema de boquillas anti-cal.
- Salida del agua por impulsos.
- Salida del agua en forma de lluvia.
- Salida del agua en forma de lluvia aireada.
- Resistente al choque térmico y químico antilegionela.
- Garantía de 3 años en complementos.
- Superficie cromada: 15 micras de espesor de níquel, 0.3 micras de cromo.

Ensayos

- Ensayos de corrosión según las exigencias de la Norma Europea EN 248.

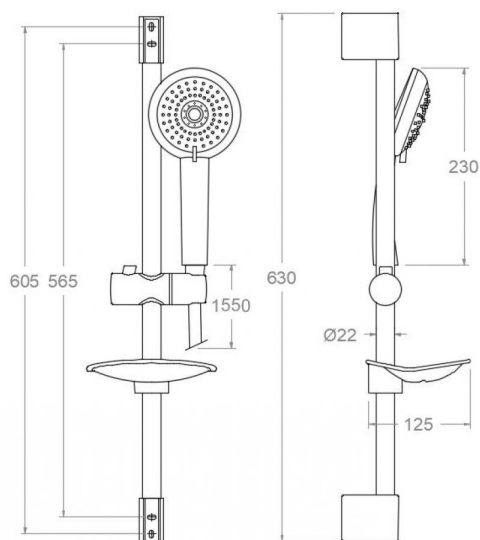



Slide bar Polo set, with handshower 3 functions Ø90mm and flexible hose, chromed
982402AS

Collection: Accessories	Finish: Chrome	Code: 300180
Location: Bath	Category: Shower	

Technical characteristics

- Anti-limescale nozzles system.
- Water outlet by impulses.
- Water outlet with rain effect.
- Water outlet with airy rain effect.
- Thermal shock resistant and anti-Legionella chemical.
- Guarantee of 3 years for accessories.
- Chromed surface: 15 microns thick of nickel and 0.3 microns thick of chrome.

Tests

- Corrosion test according to european standard EN 248.

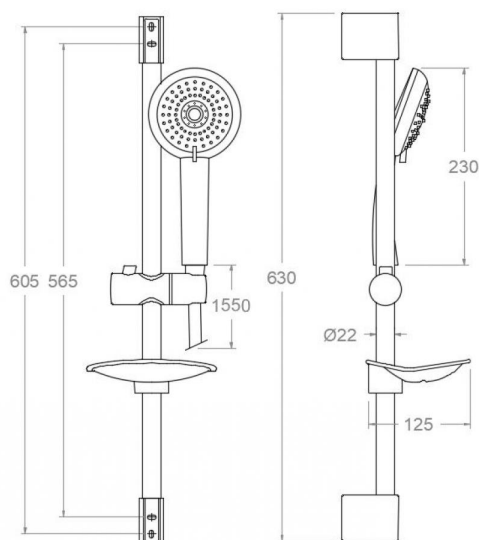



Barre de douche en métallique Polo avec douchette 3 positions Ø90mm et flexible, chromée
982402AS

Collection:	Fini:	Code:
Accessoires	Chrome	300180
Lieu:	Catégorie:	
Bain	Douche	

Caractéristiques techniques

- Picots anti-calcaire.
- Sortie d'eau par impulsions.
- Sortie d'eau sous forme de pluie.
- Sortie d'eau sous forme de pluie aérée.
- Résistant au choc thermique et chimique anti-légionelle.
- Garantie de 3 ans en compléments.
- Surface chromée: 15 microns d'épaisseur de nickel, 0.3 microns de chrome.

Essais

- Essais de corrosion selon les exigences de la Norme Européenne EN 248.

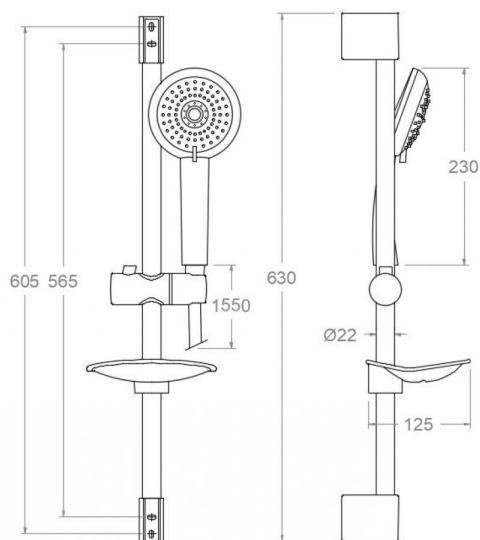



Brausestangenset Polo chrom: Brausestange 60cm,
Handbrause Ø90mm 3jet, Metall-Brauseschlauch
982402AS

Sammlung: Zubehör	Ausführung: Chrom	Code: 300180
Standort: Wannenfüll	Kategorie: Brausebatterie	

Technische eigenschaften

- Antikalksystem durch Silikonknoppen.
- Massage-Effekt.
- Regen-Effekt.
- Sanfter Regen-Effekt durch luftangereichertes Wasser.
- Widerstandsfähigkeit bei Anti-Legionellen Temperaturschock.
- 3 Jahre Garantie auf Zubehör und Komponenten.
- Zweischiichtverchromung: 15 Mikrometer Nickel, 0,3 Mikrometer Chrom.

Qualitätsprüfung

- Korrosionsprüfung gemäß europäischer Norm EN 248.

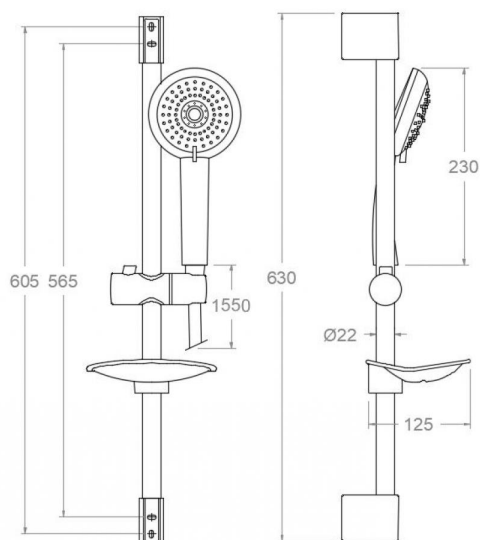

ramonsoler.

→ rsramonsoler.com