

ramonsoler.

→ Ficha Técnica
Data Sheet
Fiche Technique
Technisches Datenblatt

Accesorios



Ducha de mano rectangular con 1 función de metal, cromada 4716MR

Colección: Accesorios	Acabado: Cromo	Código: 99Z305011
Ubicación: Baño	Categoría: Ducha	

Características técnicas

- Garantía de 3 años en complementos.
- Superficie cromada: 15 micras de espesor de níquel, 0.3 micras de cromo.

Ensayos

- Ensayos de estanquidad, flexión torsión, dispersión del chorro, resistencia mecánica, caudal y corrosión, según las exigencias de las Normas Europeas EN 1112 y EN 248.

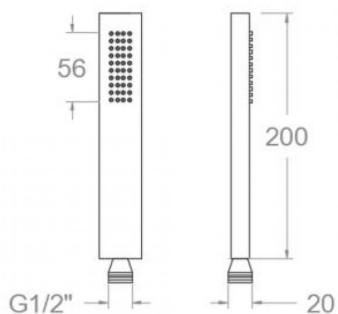



Rectangular 1-function handshower made of metal, chrome-plated
4716MR

Collection:	Finish:	Code:
Accessories	Chrome	99Z305011
Location:	Category:	
Bath	Shower	

Technical characteristics

- Guarantee of 3 years for accessories.
- Chromed surface: 15 microns thick of nickel and 0.3 microns thick of chrome.

Tests

- Water tightness, flexion and torsion, outlet dispersion, mechanical resistance, flow rate and corrosion test according to european standards EN 1112 and EN 248.

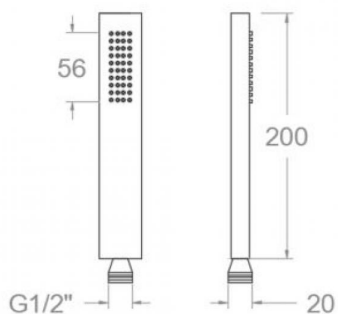

**4716 MR CHROMÉ DOUCHE RECTANGULAIRE MÉTALLIQUE
4716MR**

Collection: Accessoires	Fini: Chrome	Code: 99Z305011
Lieu: Bain	Catégorie: Douche	

Caractéristiques techniques

- Garantie de 3 ans en compléments.
- Surface chromée: 15 microns d'épaisseur de nickel, 0.3 microns de chrome.

Essais

- Essais d'étanchéité, flexion de torsion, dispersion de jet, résistance mécanique, débit et corrosion, selon les exigences des Normes Européenne EN 1112 et EN 248.

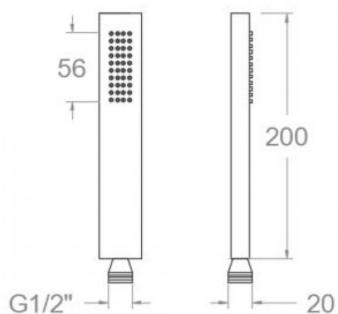



4716 MR HANDBRAUSE METALL CHROM ANTIKALKSYSTEM 4716MR

Sammlung: Zubehör	Ausführung: Chrom	Code: 99Z305011
Standort: Wannenfüll	Kategorie: Brausebatterie	

Technische eigenschaften

- 3 Jahre Garantie auf Zubehör und Komponenten.
- Zweischichtverchromung: 15 Mikrometer Nickel, 0,3 Mikrometer Chrom.

Qualitätsprüfung

- Dichtheits-, Biegungs-, Torsions-, Wasserstrahl-, mechanisches Verhalten unter Druck, Durchfluss- und Korrosionsprüfung, gemäß den europäischen Normen EN 1112 und EN 248.

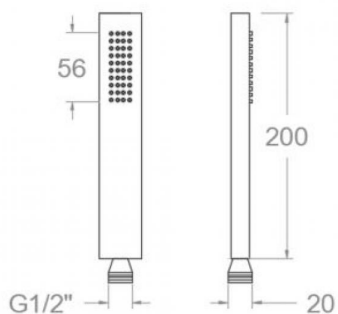

ramonsoler.

→ rsramonsoler.com